

Large Radio Frequency Ion Engines

H.W. Loeb, G.A. Popov, V.A. Obukhov, D. Feili, Ch. Collingwood, and A. Mogulkin

Summary

A large RF-ion thruster “RFIT-45”, having an ionizer diameter of 48.6 cm and consuming 35 kW of power, is described. It is scheduled to generate a thrust of 760 mN at a specific impulse of 7000 s and a lifetime of more than 50,000 hours. The beam current will be 7.0 A, the positive high voltage 4.5 kV.

A 1 MWe nuclear power plant could supply up to 30 clustered thrusters. At lifetime penalty, a thrust-enhanced single engine may generate 1.08 N at nearly 50 kW of power. To keep the lifetime specification, an enlargement of the rf-thruster (65 cm ionizer diameter and 70 kW or 80 cm and 105 kW) may reduce the number of clustered engines, too.

The RFIT-45 engine has been designed in accordance with smaller RIT-devices. A set of technical drawings is available. The scheduled performance data were derived from scaling laws of the RIT-family.

Keywords

radio frequency ion thrusters; thruster design; scaling laws; high power; high specific impulse; lunar cargo ferry; Mars excursion ship; nuclear power plant

1. Introduction

In middle 2010, the President of the Russian Federation approved the development of a 1 MWe nuclear reactor space power plant under the scientific management of the Keldysh Research Center [1].

Together with a cluster of powerful electric thrusters, a unique nuclear-electric drive would result that enables [2]:

- ambitious robotic missions within the Solar system of beyond;
- heavy cargo transport flights from low Earth orbit (LEO) (800 km) to geostationary Earth orbit (GEO) and onto Lunar surface;

- manned excursions to Mars;
- Earth protection against asteroid and comet hazard;
- removal of large space debris, etc.

The first example, a lunar cargo shuttle, has already been described [3, 4]. Figure 1 (upper drawing) shows this spacecraft equipped with a 1 MWe nuclear power plant (20 tons) at the bow, four clusters with 10 RFIT-45 thrusters, each (total EP-system mass 5.7 tons), and the 25 tons lunar descent rocket at the ship's stern. During lifetime of nuclear electric propulsion (NEP), five cargo transport flights from LEO (800 km) to low Lunar orbit (LLO) (100 km) could be done with a total payload in the low lunar orbit of 128.5 tons and with a propellant consumption of 10.8 tons per round trip.

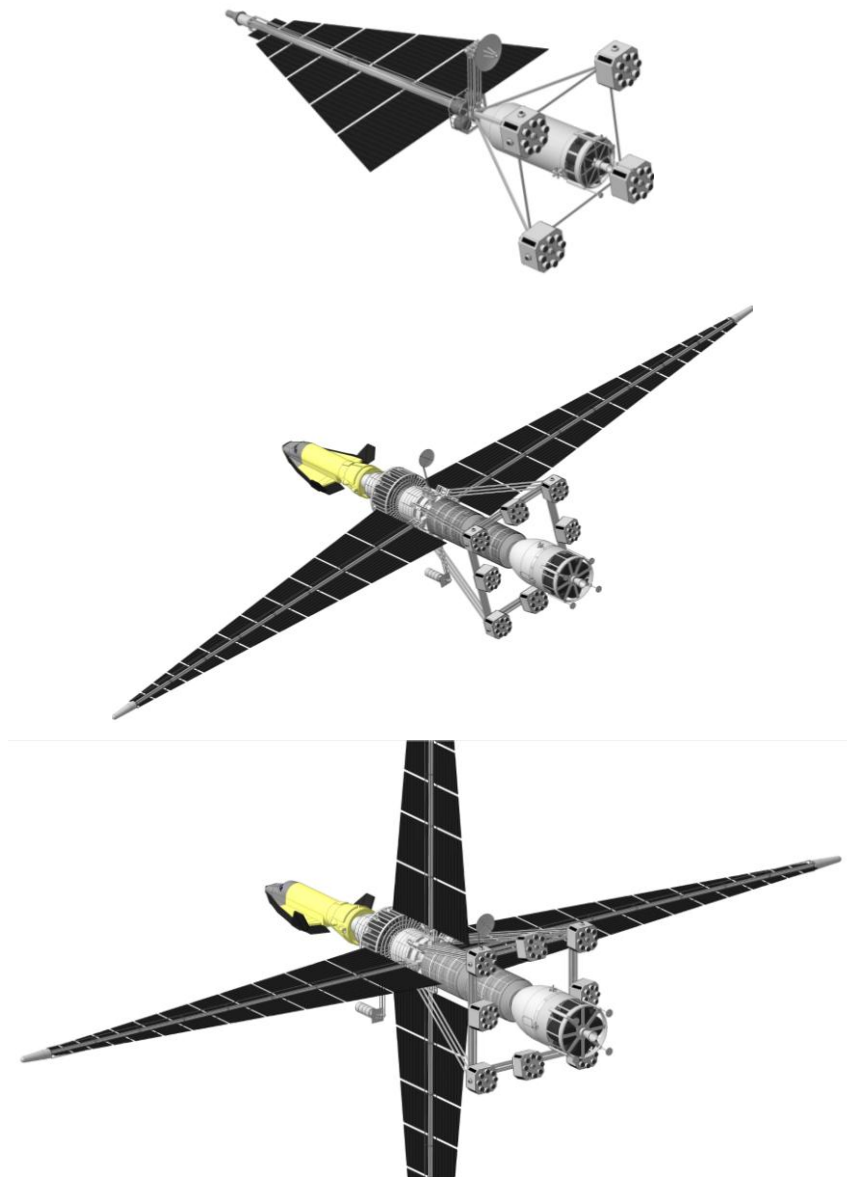

Figure 1 - Drawings of a 1 MWe lunar cargo shuttle (upper drawing), of a 2 MWe (middle) and a 4 MWe (at the bottom) manned Mars ship, all equipped with RFIT-45 ion thrusters

Figure 1 (middle and bottom drawings) shows also two manned Mars ships with 2 MWe and 4 MWe of available power, respectively. The radiators of the nuclear plants are fixed at the cylindrical cosmonaut complex. At the bow and at the stern, respectively, a shuttle for maneuvering in Earth atmosphere and the Mars descent/ascent vehicle are mounted. Mission analysis shows a launch mass of 215 tons and a 2.5 yrs round trip time [5].

All these mission examples have been based on clusters of RFIT-45 ion thrusters with the following specification:

1. PPU-power consumption - 35 kW per thruster;
2. specific impulse - 7 000 s which requires a positive high voltage of 4.5 kV; and
3. thruster lifetime – 50,000 hrs.

These specifications are very challenging and have not been realized up today. However, the RFIT-45 promises to meet them.

2. Thruster Principle

The mode of working of rf-ion thrusters has been repeatedly described (see e.g. Ref. 6) and it should only be sketched here (Figure 2).

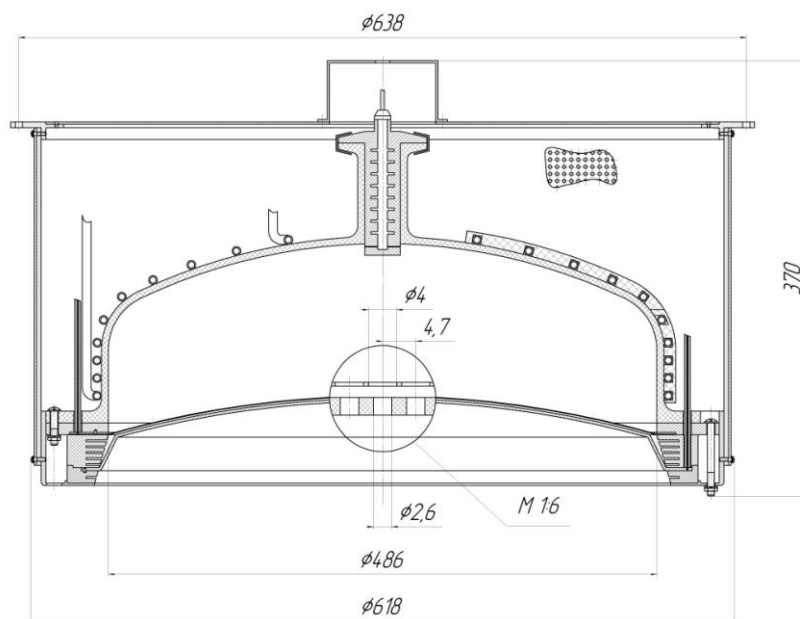

Figure 2 - Cross-section true to scale of an RFIT-45 thruster

The induction coil of a radio-frequency generator (RFG) surrounds the ionizer vessel and induces an eddy E-field which accelerates the discharge electrons up to ionizing energy in the tail of Maxwell distribution. An electrodeless, self-sustaining discharge results. Ignition is done by a short pulse of neutralizer electrons.

The Xenon-ions are extracted out of the ionizer plasma, accelerated and ion-optically focused by a dished, multihole two-grid system. The exhausted ion-beam is neutralized by electrons from a hollow cathode.

There are some conceptual advantages of the rf-ion thruster type over the stationary plasma thruster (SPT) and the Kaufman engines:

- The existence of a grid system enables to work with an accel voltage of 4.5 kV that yields the desired specific impulse of 7000 s.
- Due to ion-optical grid focusing, the sputtering rate can be strongly reduced in favor of lifetime.
- Another advantage over the SPT-type is the comparatively low operation temperature.
- Comparing with Kaufman-type ion engine, no discharge electrodes (together with their power supply and control units) must be biased on high voltage.
- No metallic parts are inside the ionizer vessel; therefore, no sputtered material like baffle flakes may cause destructive arcs between the high-voltage grids. Consequently, no reliability and safety reasons urge to operate the rf-engine in a strongly throttled mode.
- As the rf-discharge is not sensitive against oxygen impurities, the Xenon must not be of extremely high purity; this would lower the propellant cost remarkably.
- Finally, the mechanical set up, the power supply and control are relatively simple.

On the other hand, some conceptual drawbacks had to be considered and removed, namely the somewhat complicated coupling of the rf-discharge energy from the outside into the plasma, the rf-energy losses outside the plasma, and the initially feared electromagnetic interference (EMI) problems.

3. Thruster Design

The general design of RFIT-45 resembles that of the RIT-22 engine, but it had to be modified.

The isolator in the propellant injector must now guarantee a break-through stability of higher than 4.5 kV.

The special shape of the alumina discharge vessel (see Figure 2) should not only minimize the plasma-wall losses, but also improve the vibration stability.

The diameter of the ionizer $2R$ is 486 mm. The optimum length is now 130 mm according to a scaling law (for Xenon): $l_{opt} = (2R)^{0.066}$.

The 10 turns of the induction coil are tightly wound around the ionizer vessel and fixed by 6 “combs”. The coil is connected to a nearby placed rf-generator (700 kHz, max. 3 kW).

The two-grid system (+4.5 kV/-0.5 kV) has been calculated with respect to RIT-22 (+2.1 kV/-0.215 kV) by another scaling law: $\beta \sim j_i^{-1/2} U_{ex}^{3/4}$, which had been proven by ion trajectory calculation (IGUN program).

As a result, the grid system has 8583 beamlet holes and an inward dishing radius of 80 cm. The emission or screen grid is made of a 0.55 mm thin Molybdenum, Titanium or Carbon fiber sheet and has 4.0 mm diameter holes. The accelerator grid is made of graphite or Carbon fiber and is 2.5 mm thick. The borings vary from axis to wall from 2.5 mm to 2.8 mm in diameter.

Figure 3 shows technical drawings of the thruster.

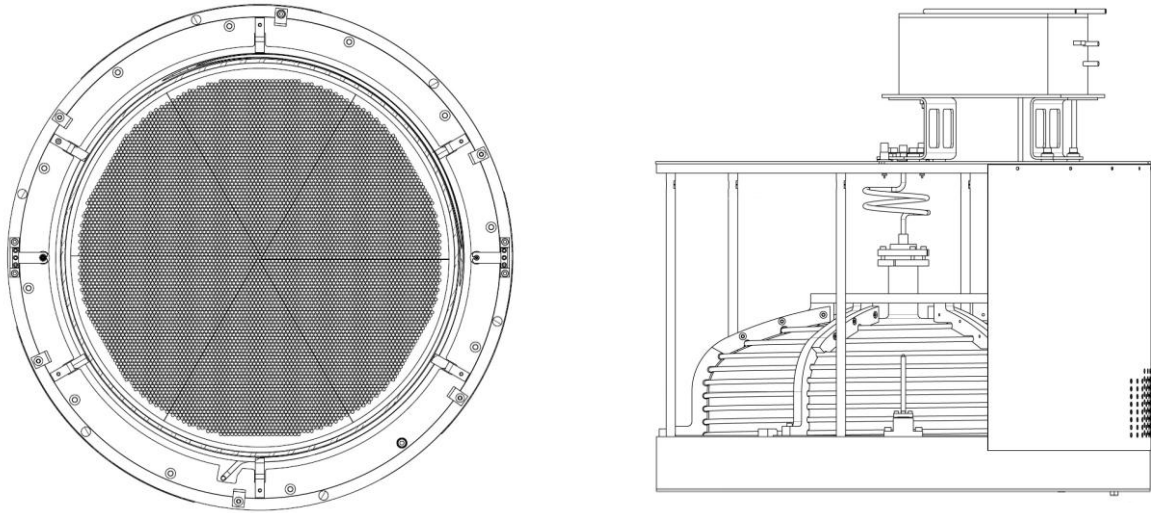

Figure 3 - Technical drawings of the RFIT-45 thruster

4. Thruster Performance

By using a scaling diagram with experimentally found optimum data of rf-frequency, gas pressure, ion production costs etc. (Figure 4) ranging from the microthruster RIT-2.5 to the RIT-22 engine, expected data of the RFIT-45 followed. Together with the specification values, the known formulas enabled us to calculate the performance data (Table 1), e.g. the thrust of about 760 mN and the overall efficiency (including divergency) of nearly 79 %.

The lifetime T has been estimated by using the empirically found lifetime of RIT-10 and RIT-22 and by considering the determining factors of sputtering rate Y , charge exchange cross section q_{cex} , neutral gas density n_0 , and beam current density j_i in the grid system:

$$T \sim (Yq_{cex}n_0j_i)^{-1}. \text{ For RFIT-45, one gets } T = 56,500 \text{ hrs} = 6.45 \text{ yrs.}$$

If some missions don't need such a long lifetime like e.g. a round trip to Mars, the engine could be operated in a thrust augmented mode with up to $P = 50$ kW of PPU input. The related data are given in Table 1 in brackets. Roughly, we may count with $T \sim 1/P^2$.

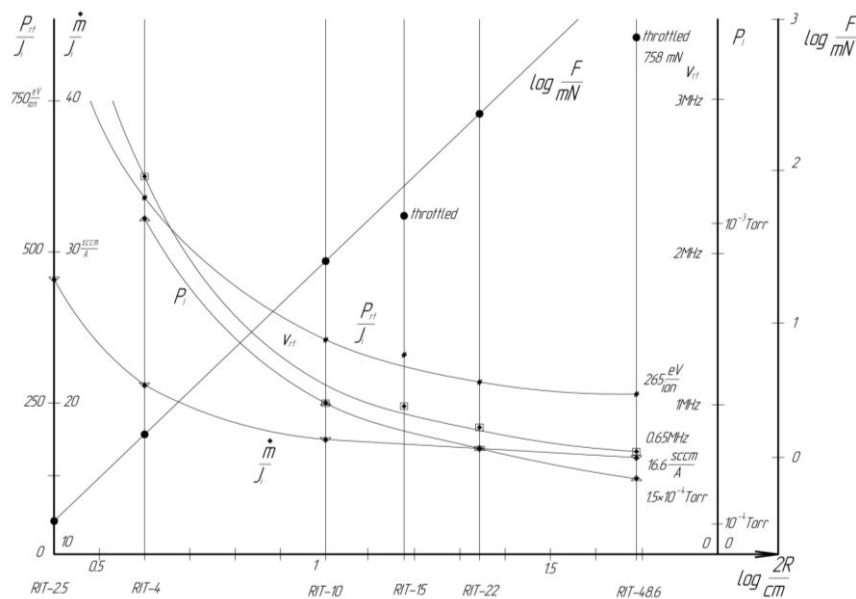

Figure 4 - Ion production costs P_{rf}/J_i , specific propellant consumption \dot{m} / J_i , gas pressure in the ionizer P_i , rf-frequency V_{rf} , and logarithm of thrust F vs. the logarithm of ionizer diameter $2R$, used to predict the relative data of RFIT-45

Table 1

Scheduled performance data of the 35 kW rf-ion thruster RFIT-45 (the data in brackets give the thrust augmented operation with half lifetime)

positive high voltage	+4.5 kV
rf-discharge power	1.85 (2.64) kW
discharge gas pressure	$1.5 (2.1) \times 10^{-4}$ Torr
beam current	7 (10) A
ion production cost	265 eV/ion
current density at 1-st grid	6.5 (9.25) mA/cm ²
thruster power input*	33.4 (47.6) kW
PPU power input*	35.1 (50) kW
propellant flow rate*	11.3 (16.1) mg/s
power efficiency*	94.9 %
propellant mass efficiency*	84.1 %
overall efficiency*	78.6 %
thrust	758 (1080) mN
specific impulse	6880 s
lifetime	56,500 (27,800) hr
* Without neutralizer which is considered as a separate unit	

Naturally, the RFIT-engine may be also enlarged if higher thrust levels per unit should be required, i.e. if the number of clustered engines should be reduced. E.g., a 65 cm or even an 80 cm thruster could be built if 70 kW or 105 kW power levels would be needed. The engines' thrust would be 1.52 N or 2.27 N, respectively; the specific impulse would increase from 6880 s to 7120 s or 7320 s and the overall efficiency from 78.6 % to 81.3 % or 83.5 %, respectively. However, the

development and qualification costs would increase roughly with the third power of the diameter which makes a further scaling up not very attractive.

5. Conclusion and Outlook

The thruster RFIT-45 has been designed and promises to meet the specifications. As the next step, a demonstration model should be building and testing. Considering the great German experiences with rf-ion thrusters, Russian-German cooperation would be possible and recommendable.

Acknowledgement

This work has been done at RIAME/MAI by a grant № 11.G34.21.0022 given by the Russian Ministry of Education and Science which is gratefully acknowledged.

References

1. И. Афанасьев «Ядерный космос России» Новости космонавтики, № 2, 2010.
2. А.С. Коротеев, В.Н. Акимов, С.А. Попов «Проект создания транспортно-энергетического модуля на основе ядерной энергодвигательной установки мегаваттного класса», журнал «Полет», № 4, стр. 93-99, 2011.
3. H.W. Loeb, D. Feili, G.A. Popov, V.A. Obukhov, V.V. Balashov, A.I. Mogulkin, V.M. Murashko, A.N. Nesterenko, and S.A. Khartov: “Design of High-Power High-Specific Impulse RF-Ion Thruster”, 32nd IEPC, Wiesbaden, Sept. 11-15, 2011.
4. H.W. Loeb and V.G. Petukhov: “Analysis of a Possible Lunar Transfer Vehicle Using Nuclear Electric Propulsion”, prepared for publishing 2012.
5. M.S. Konstantinov and V.G. Petukhov: “The Analysis of One Concept of Manned Mission to Mars”, 61st IAF Congress, IAC-10-A5.4.6. Sept./Oct. 2010.
6. H.W. Loeb, J. Freisinger, K.H. Groh, and A. Scharmann: “State-of-the-Art of the RF-Ion Thrusters and Their Applications”, IAC-88-258, 39th IAF Congress, Bangalore, 1988.

Сведения об авторах

Dr. Horst Wolfgang LOEB, Professor, Justus-Liebig-Universität, I. Physikalisches Institut.
Heinrich-Buff-Ring 16, 35392 Gießen

Dr. Garri A. POPOV, Professor, academic of RAS, RIAME MAI Director,
MAI, Volokolamskoye sh., 4, Moscow, Russian Federation, A-80, GSP-3, 125993;
e-mail: riame@sokol.ru

Dr. Vladimir A. OBUKHOV, senior research scientist, RIAME MAI, Deputy Director.
MAI, Volokolamskoye sh., 4, Moscow, Russian Federation, A-80, GSP-3, 125993;
e-mail: riame@sokol.ru

Dr. Davar FEILI, Justus-Liebig-Universität, I. Physikalisches Institut.
Heinrich-Buff-Ring 16, 35392 Gießen;
e-mail: davar.feili@exp1.physik.uni-giessen.de

Dr. Cheryl COLLINGWOOD, Justus-Liebig-Universität, I. Physikalisches Institut.
Heinrich-Buff-Ring 16, 35392 Gießen;
e-mail: cheryl.collingwood@physik.uni-giessen.de

Andrey I. MOGULKIN, Engineer of RFIT MAI.
MAI, Volokolamskoye sh., 4, Moscow, Russian Federation, A-80, GSP-3, 125993;
e-mail: riame@sokol.ru